

FEATURES

- ❑ New generation switching technology
- ❑ Regulated 24V DC output voltage
- ❑ Universal AC input (85V AC to 265V AC)
- ❑ Low conducted EMI due to frequency jittering
- ❑ Short-circuit protection
- ❑ Overload protection
- ❑ Compact size, Light weight
- ❑ Low cost, High efficiency
- ❑ Smart switching



The PS242 - 24V, 2A SMPS Power Supply is designed using new generation switching technology which provides higher efficiency within low cost. It meets the demands of high quality level, integration and performance which are required by today's applications. The use of SMPS technology minimizes use of lossy components such as resistors and uses components that are ideally lossless such as switches, capacitors, inductors, and transformers, thus providing better efficiency. The power supply uses the new generation TOPSwitch-GX technology for reduced component count and high reliability. Flyback topology is used which gives input-to-output isolation. Smaller size and lighter weight are the features of the SMPS Power Supply. It has overload protection, overvoltage protection, undervoltage protection and short-circuit protection in order to safeguard the equipment.

SPECIFICATIONS:

INPUT	
Input voltage	Universal input: 85 V AC to 265 V AC
Typical Efficiency	77% Minimum
Overvoltage protection	Provided
OUTPUT	
Voltage rating	24 V DC +/- 0.5V
Current rating	2 A
Ripple & Noise voltage	125 mVpp max.
Overload protection	Provided
Short circuit	Provided
Line regulation	+/- 0.5%
Load regulation	+/- 0.5%
GENERAL	
Operational Indicator	LED
Termination	PCB mounted screw terminal
Enclosure	MS enclosure – IP10
Mounting	Back panel mounting
Weight	1 kg (approx.)
Dimensions	162 (W) × 75 (H) × 55 (D)
ENVIRONMENTAL	
Operational Temperature	-10 to 60 deg. C
Storage Temperature	-30 to 85 deg. C

DIMENSIONS in mm:

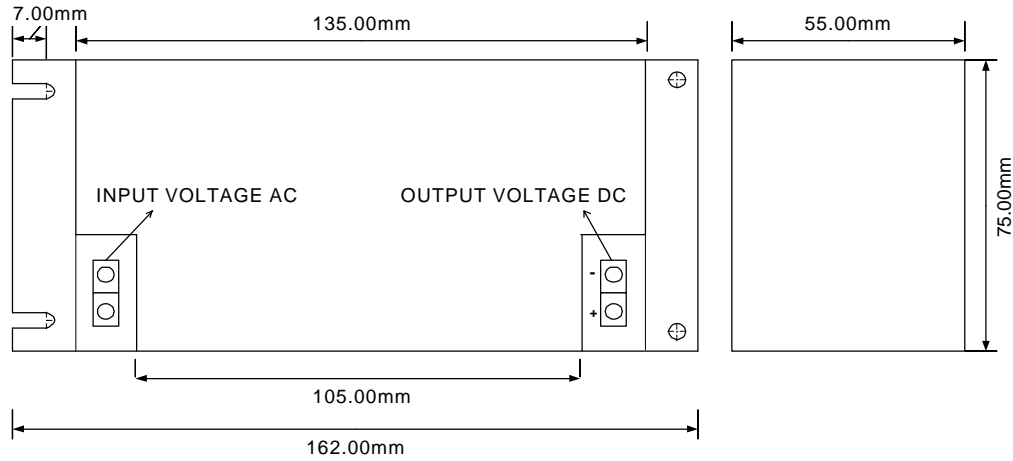

MOUNTING DETAILS:

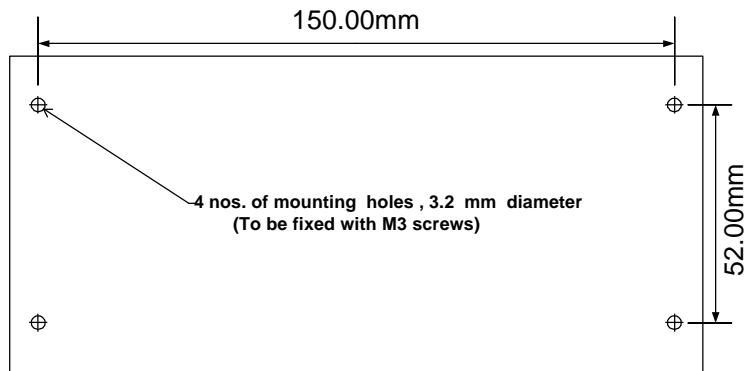

ORDERING CODE:

9 2 3 - 0 0 0 - 0 0

MICRO SYSTEMS & CONTROLS

26 Lake East 4th Road
Santoshpur, Kolkata 700075, India

Ph: (033)-2416-3135 / 2416-8933 Fax: +91-33-2416-8933, +91-33-2416-3135

Email: sales@mscontrols.com

Web: <http://www.mscontrols.com>

As product development is a continuous process, information in this catalog is subject to change without notice.

2005.07